

PRESSURE SETS WITH VESSEL



HYDROFRESH 24 SF



HYDROFRESH 24 CL



HYDROFRESH 60 CL

PERFORMANCE

MODEL	POWER		FLOW RATE (1) l/min	SETTING (2) bar
	kW	HP		
HYDROFRESH 24 SF				
PKm 60 - 24 SF	0.37	0.50	32	1.4 ÷ 2.8
PKm 65 - 24 SF	0.50	0.70	40	1.5 ÷ 3.0
JSWm 1CX - 24 SF	0.37	0.50	45	1.2 ÷ 2.6
JSWm 1BX - 24 SF	0.50	0.70	50	1.4 ÷ 2.8
JSWm 1AX - 24 SF	0.60	0.85	50	1.8 ÷ 3.2
JSWm 10MX - 24 SF	0.75	1	80	1.4 ÷ 2.8
JSWm 12MX - 24 SF	0.90	1.25	80	2.0 ÷ 3.5
JSWm 15MX - 24 SF	1.1	1.5	80	2.5 ÷ 4.0
HYDROFRESH 24 CL				
PKm 60 - 24 CL	0.37	0.50	32	1.4 ÷ 2.8
PKm 65 - 24 CL	0.50	0.70	40	1.5 ÷ 3.0
CPm 158 - 24 CL	0.75	1	90	1.8 ÷ 3.2
CPm 170 - 24 CL	1.1	1.5	120	2.2 ÷ 3.5
JSWm 1BX - 24 CL	0.50	0.70	50	1.4 ÷ 2.8
JSWm 1AX - 24 CL	0.60	0.85	50	1.8 ÷ 3.2
JSWm 10MX - 24 CL	0.75	1	80	1.4 ÷ 2.8
JSWm 12MX - 24 CL	0.90	1.25	80	2.0 ÷ 3.5
JSWm 15MX - 24 CL	1.1	1.5	80	2.5 ÷ 4.0
JCRm 1B - 24 CL	0.50	0.70	50	1.4 ÷ 2.8
JCRm 1A - 24 CL	0.60	0.85	50	1.8 ÷ 3.2
JCRm 10M - 24 CL	0.75	1	80	1.4 ÷ 2.8
JCRm 15M - 24 CL	1.1	1.5	80	2.5 ÷ 4.0
HYDROFRESH 60 CL				
JSWm 10MX - 60 CL	0.75	1	80	1.4 ÷ 2.8
JSWm 12MX - 60 CL	0.90	1.25	80	2.0 ÷ 3.5
JSWm 15MX - 60 CL	1.1	1.5	80	2.5 ÷ 4.0

COMPONENTS:

- Single-phase pump
- Tank
- Pressure switch
- Pressure gauge
- Hose (for 24CL and 60CL)
- Brass connector
- 1.5 m power cable with Schuko plug

(1) Maximum flow rate at the minimum recommended pressure switch pressure

(2) Recommended pressure range

DIMENSIONS AND WEIGHT

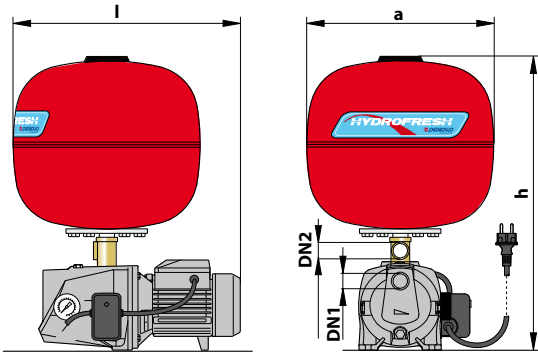

MODEL	PORTS		DIMENSIONS mm			WEIGHT kg
	DN1	DN2	l	a	h	
PKm 60 - 24 SF	1"	1"	360	360	522	12.5
PKm 65 - 24 SF	1"	1"	373	360	530	13.9
JSWm 1CX - 24 SF	1"	1"	437	360	551	16.5
JSWm 1BX - 24 SF	1"	1"	437	360	551	17.3
JSWm 1AX - 24 SF	1"	1"	437	360	551	17.6
JSWm 10MX - 24 SF	1"	1"	463	360	572	21.0
JSWm 12MX - 24 SF	1"	1"	463	360	572	22.0
JSWm 15MX - 24 SF	1"	1"	463	360	572	22.4

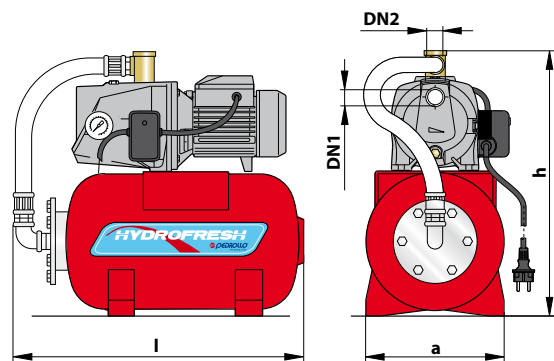

MODEL	PORTS		DIMENSIONS mm			WEIGHT kg
	DN1	DN2	l	a	h	
PKm 60 - 24 CL	1"	1"	540	255	503	13.2
PKm 65 - 24 CL	1"	1"	540	255	508	14.8
CPm 158 - 24 CL	1"	1"	540	255	585	19.9
CPm 170 - 24 CL	1¼"	1"	540	255	605	26.3
JSWm 1BX - 24 CL	1"	1"	540	265	486	17.9
JSWm 1AX - 24 CL	1"	1"	540	265	486	18.2
JSWm 10MX - 24 CL	1"	1"	540	315	507	21.6
JSWm 12MX - 24 CL	1"	1"	540	315	507	22.6
JSWm 15MX - 24 CL	1"	1"	540	315	507	23.0
JCRm 1B - 24 CL	1"	1"	540	255	519	14.3
JCRm 1A - 24 CL	1"	1"	540	255	519	14.8
JCRm 10M - 24 CL	1¼"	1"	540	255	551	17.3
JCRm 15M - 24 CL	1¼"	1"	540	255	551	18.4

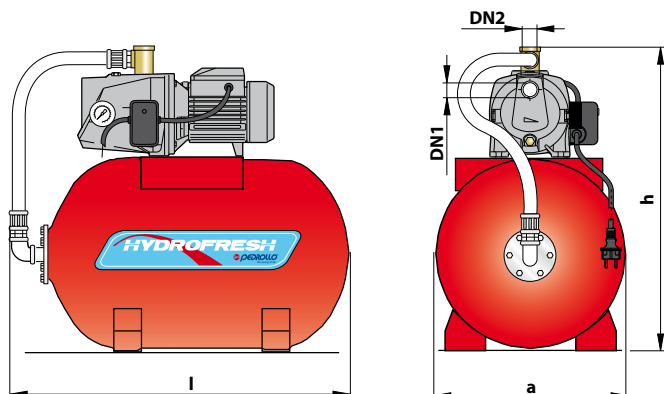

MODEL	PORTS		DIMENSIONS mm			WEIGHT kg
	DN1	DN2	l	a	h	
JSWm 10MX - 60 CL	1"	1"	750	380	647	28.2
JSWm 12MX - 60 CL	1"	1"	750	380	647	29.2
JSWm 15MX - 60 CL	1"	1"	750	380	647	29.6